

ZXCT1012

Reduced height micro-power current monitor

Description

The ZXCT1012 is a high side current sense monitor. Using this type of device eliminates the need to disrupt the ground plane when sensing a load current.

The ZXCT1012 takes the voltage developed across a small value resistor and translates it into a proportional output current. A user defined output resistor scales the output current into a ground referenced voltage.

The ZXCT1012 has the accuracy specification of the ZXCT1010 but in TSOT23-5, and TDFN3x3-5.

Features

- 2.5V to 20V supply range
- 3.5 μ A quiescent current
- Current output - user set gain
- Thin package - TSOT23-5 and TDFN3x3-5
- Temperature range -40 to 85°C

Pin connections

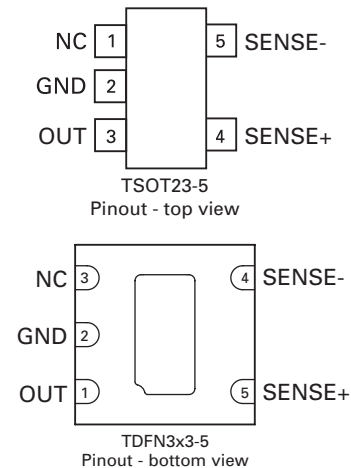

A minimum operating current of just 3.5 μ A, combined with its TSOT23-5 package make it suitable for portable battery equipment where size and current consumption are critical.

The wide input voltage range down to as low as 2.5V make it suitable for a wide range of applications requiring direct operation from a battery.

Applications

- Battery fuel gauge
- Battery chargers
- Overcurrent monitor
- Power management

Applications circuit

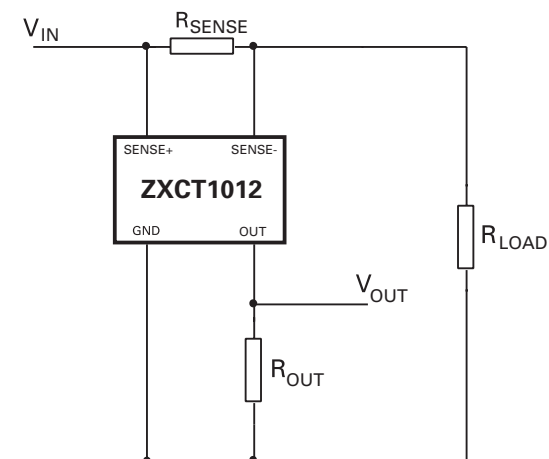

Ordering information

Device	Package	Status	Device marking	Reel size (inches)	Tape width (mm)	Quantity per reel
ZXCT1012DAATA	TDFN-5 (3mm x 3mm)	Active	1012	7	8	3000
ZXCT1012ET5TA	TSOT23-5	Active	1012	7	8	3000

Pin information

Pin		Name	Description
TDFN5	TSOT23-5		
3	1	N/C	No connection
2	2	GND	Ground connection
1	3	OUT	Output current pin. Current generated due to a difference voltage between V_{SENSE+} and V_{SENSE-} flows out of this pin. A suitable value resistor connected to ground creates an output voltage. The maximum voltage out of this pin will be $V_{SENSE-} - 1.5V$.
5	4	SENSE+	This pin should be connected to the rail whose current is being measured and also provides power to internal circuitry. It is the positive input of the current monitor and has an input range from 20V down to 2.5V. The current through this pin varies with differential sense voltage.
4	5	SENSE-	This is the negative input of the current monitor and has an input range from 20V down to 2.5V.

Absolute maximum ratings

V_{SENSE+} max.	20V
Voltage on any pin (relative to GND pin)	-0.6 and $V_{SENSE+} + 0.5V$
$V_{SENSE}^{(\ddagger)}$	-0.15V to +3V
Ambient operating temperature range	-40 to 85°C
Storage temperature	-55 to 150°C
Maximum junction temperature	150°C
Package power dissipation	300mW at $T_{amb} = 25^\circ C$ (De-rate to zero at 150°C)

Package	$R_{\theta JA}$	P_{DISS} at 25°C
TSOT23-5 ^(*)	250°C/W	500mW
TDFN3x3 5 pin ^{(*) (†)}	232°C/W	540mW

NOTES:

(*) Mounted on 30mm x 16mm x 1.1mm FR4 board with 1oz copper.

Operation above the absolute maximum rating may cause device failure.

Operation at the absolute maximum ratings, for extended periods, may reduce device reliability.

NOTES:

(‡) V_{SENSE} is defined as the differential voltage between the SENSE+ and SENSE- pins.

$$V_{SENSE} = V_{SENSE+} - V_{SENSE-}$$

(†) Exposed lead not connected to thermal plane

Recommended operating conditions

Symbol	Recommended parameter	Limits		
		Min.	Max.	Units
V_{IN}	Sense+ range	2.5	20	V
T_A	Ambient temperature range differential	-40	85	°C
V_{SENSE}	Sense voltage	10	2500	mV
V_{OUT}	Output voltage swing	0	$V_{SENSE-} - 1.5$	V

Electrical characteristics

Test conditions $T_{amb} = 25^{\circ}\text{C}$, $V_{IN} = V_{SENSE+} = 5\text{V}$, unless otherwise stated

Symbol	Parameter	Conditions	Limits			Unit
			Min.	Typ.	Max.	
I_{OUT}	Output current	$V_{SENSE} = 0\text{V}$	0	0.3	15	μA
		$V_{SENSE} = 10\text{mV}$	85	100	115	μA
		$V_{SENSE} = 40\text{mV}$	380	400	420	μA
		$V_{SENSE} = 100\text{mV}$	0.975	1.00	1.025	mA
		$V_{SENSE} = 200\text{mV}$	1.95	2.00	2.05	mA
I_Q	Ground pin current	$V_{SENSE} = 0\text{V}$		3.5	8	μA
I_{SENSE-}	SENSE- pin input current				100	nA
Acc	Accuracy	$R_{SENSE} = 0.1\text{V}$ $V_{SENSE} = 200\text{mV}$	-2.5		2.5	%
Gm	Transconductance, $I_{OUT}/V_{SENSE}^{(*)}$			10		mA/V
T_c	Temperature coefficient	$V_{SENSE} = 200\text{mV}$ $T_{amb} = 0 \text{ to } 50^{\circ}\text{C}^{(*)}$		500		ppm/ °C
BW	Bandwidth	$C_L = 5\text{pF}$, $R_{OUT} = 1\text{k}\Omega$		300		kHz
			$V_{SENSE} = 10\text{mV}$ $V_{SENSE} = 100\text{mV}$	2		MHz
CMRR ^(‡)	Common mode rejection ratio	$V_{SENSE} = 100\text{mV}$, $R_{OUT} = 1\text{k}\Omega$ $V_{IN} = 2.5\text{V to } 20\text{V}$		80		dB

NOTES:

(*) Temperature dependent measurements are extracted from characterisation and simulation results.

(‡) With the ZXCT1012 using SENSE+ as its power supply pin, common mode rejection cannot be distinguished from power supply rejection.

Typical characteristics

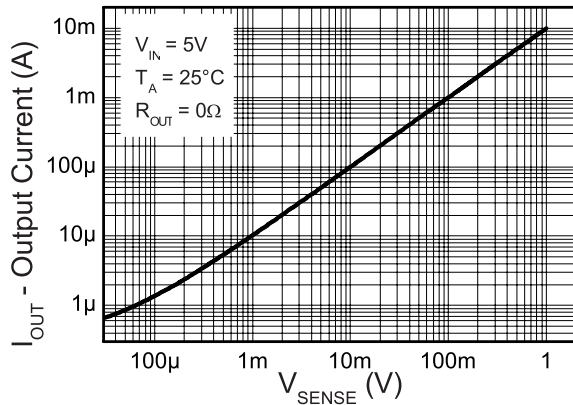

Typical Output v Sense Voltage

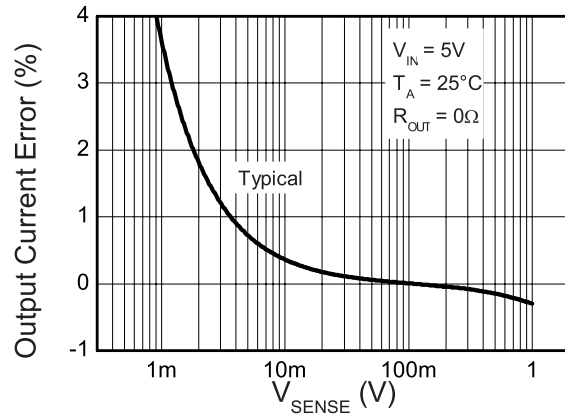

Error v Sense Voltage

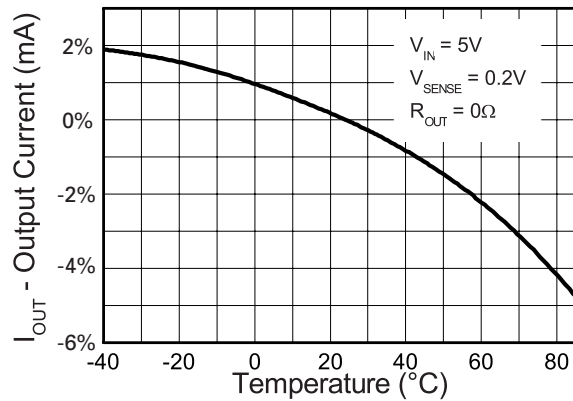

Output Current v Temperature

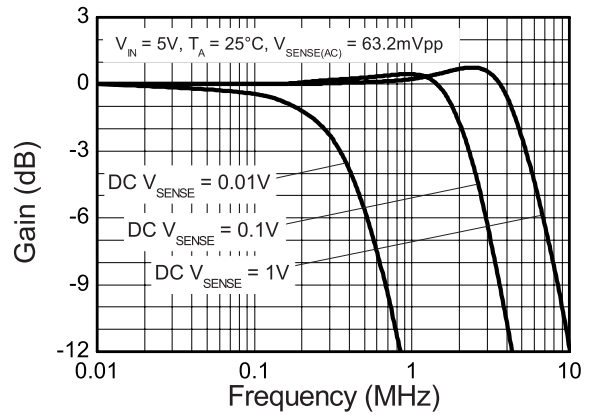

Frequency Response

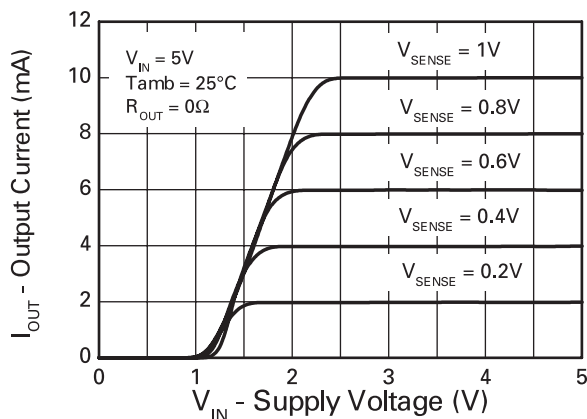

Transfer Characteristic

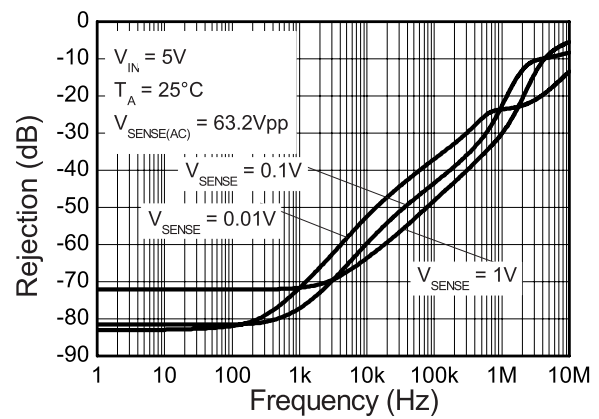

Common Mode Rejection

Applications information

The ZXCT1012 current monitor works by converting the voltage developed across a small sense resistor into a current on the out pin. In reality it is a voltage to current converter. This output current can be converted into a voltage simply by passing it through a resistor (R_{OUT}) to ground.

The current monitor has a transconductance of 10mA/V. But the overall amplifying conversion is affected by both the R_{SENSE} and R_{OUT} .

The gain equation of the ZXCT1012 is:

$$V_{OUT} = I_L \times R_{SENSE} \frac{R_{OUT}}{100}$$

For best performance R_{SENSE} should be connected as close to the SENSE+ (and SENSE-) pins; which minimizes any series resistance with R_{SENSE} and potential for interference pickup.

When choosing appropriate values for R_{SENSE} a compromise must be reached between in-line signal loss (including potential power dissipation effects) and small signal accuracy.

Higher values for R_{SENSE} gives better accuracy at low load currents by reducing the inaccuracies due to internal offsets. For best operation the ZXCT1012 has been designed to provide best performance with V_{SENSE} of the order of 40mV to 200mV.

Current monitors are single supply devices which means they tend to saturate at very low sense voltages. However it does mean the output can never go negative. Also the output can never change direction (monotonic). This is important if the current monitor is used in a control loop.

As the sense voltage is reduced the output will tend to saturate as the input offset voltage starts to have greater effect. It is recommended to have a minimum sense voltage of 10mV to minimize linearity errors. Zetex has specified the output voltage at V_{SENSE} of 10mV, 40mV, 100mV and 200mV; which is the recommended sense voltage range.

The maximum differential input voltage, V_{SENSE} , is 2.5V; however this will cause large output currents to flow increasing power dissipation in the chip. The sense voltage can be increased further, without damaging the ZXCT1012, by the inclusion of a resistor, R_{LIM} , between SENSE- pin and the load. Typical values around 10k Ω . See figure below.

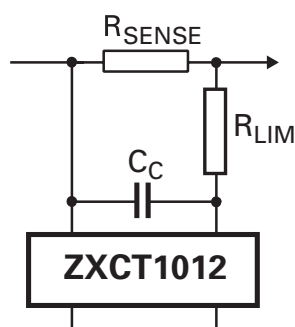

If large reverse currents are expected then the resistor, R_{LIM} , will provide protection from exceeding absolute maximum ratings.

A suitable value for R_{LIM} can be determined from:

$$R_{LIM} \gg \frac{V_{SENSE(REF)}}{5mA}$$

Where $V_{SENSE(REV)}$ is the maximum expected reverse sense voltage generated.

The following lines describe how to scale a load current to an output voltage.

$$V_{\text{SENSE}} = R_{\text{SENSE}} \times I_{\text{LOAD}} \quad \text{equation (1)}$$

$$I_{\text{OUT}} = 10\text{mA/V} \times V_{\text{SENSE}} \quad \text{equation (2)}$$

$$V_{\text{OUT}} = I_{\text{OUT}} \times R_{\text{OUT}} \quad \text{equation (3)}$$

Design example

In the circuit below a 1A current is to be represented by a 100mV output voltage (V_{OUT}):

A) To be within recommended values choose the value of R_{SENSE} to give:

$50\text{mV} > V_{\text{SENSE}} > 200\text{mV}$ at full load.

For example set $V_{\text{SENSE}} = 100\text{mV}$ at 1.0A.

From equation (1)

$$R_{\text{SENSE}} = 0.1\text{V}/1.0\text{A} = 0.1\Omega$$

B) Now choose R_{OUT} to give:

$V_{\text{OUT}} = 100\text{mV}$, when $V_{\text{SENSE}} = 100\text{mV}$.

From equation (2)

$$I_{\text{OUT}} = 10\text{mA/V} \times 0.1 = 1\text{mA}$$

Rearranging equation (3) for R_{OUT} gives:

$$R_{\text{OUT}} = V_{\text{OUT}}/I_{\text{OUT}} = 0.1/0.001 = 100\Omega$$

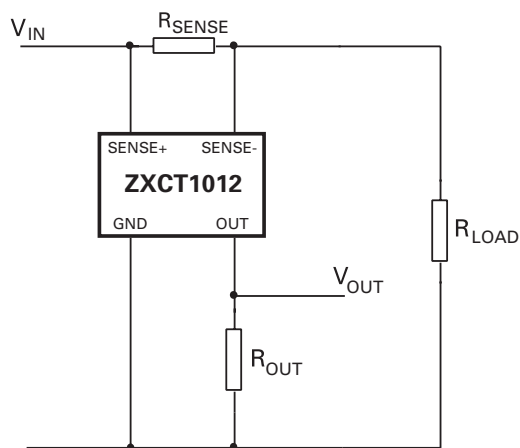

$$= 0.1 / (0.1 \times 0.01) = 100\Omega$$

Typical circuit application

Where R_{LOAD} represents any load including DC motors, a charging battery or further circuitry that requires monitoring, R_{sense} can be selected on specific requirements of accuracy, size and power rating.

Power dissipation

The maximum allowable power dissipation of the device for normal operation (P_{MAX}), is a function of the package junction to ambient thermal resistance (Θ_{JA}), maximum junction temperature (T_{JMAX}), and ambient temperature (T_{amb}), according to the expression:

$$P_{MAX} = (T_{JMAX} - T_{amb}) / \Theta_{JA}$$

The device power dissipation, P_D is given by the expression:

$$P_D = I_{OUT} \cdot (V_{IN} - V_{OUT}) \text{ watts}$$

Care must be taken when using this device at large input voltages and large sense voltages to prevent too much power dissipation.

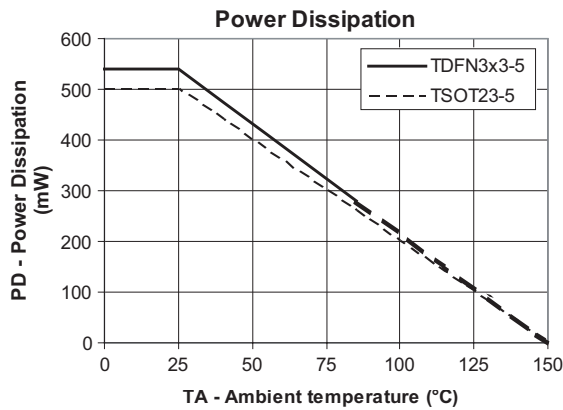

$$V_{IN} = 20V \quad V_{SENSE} = 2.5V$$

$$R_{OUT} = 100\Omega$$

$$I_{OUT} = 2.5 \times 0.01$$

$$= 25mA$$

$$V_{OUT} = I_{OUT} \times R_{OUT}$$

$$= 25mA \times 100\Omega$$

$$= 2.5V$$

$$\therefore P_D = 25mA (20 - 2.5)V$$

$$= 438mW$$

ZXCT1012

Package outline - TSOT23-5

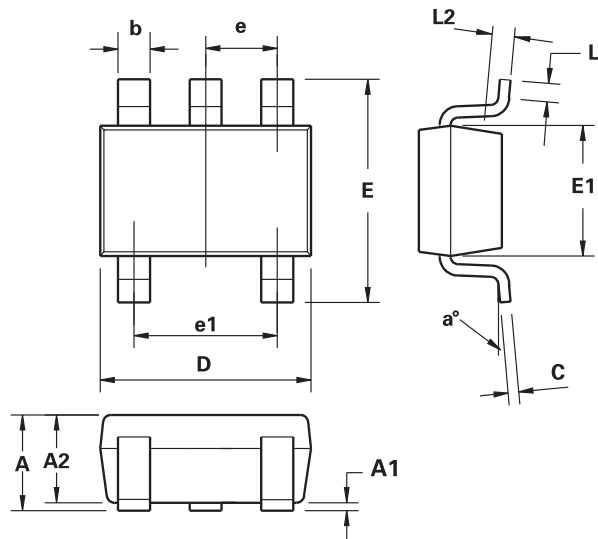

DIM	Millimeters		Inches	
	Min.	Max.	Min.	Max.
A	-	1.00	-	0.0393
A1	0.01	0.10	0.0003	0.0039
A2	0.84	0.90	0.0330	0.0354
b	0.30	0.45	0.0118	0.0177
c	0.12	0.20	0.0047	0.0078
D	2.90 BSC		0.114 BSC	
E	2.80 BSC		0.110 BSC	
E1	1.60 BSC		0.062 BSC	
e	0.95 BSC		0.0374 BSC	
e1	1.90 BSC		0.0748 BSC	
L	0.30	0.50	0.0118	0.0196
L2	0.25 BSC		0.010 BSC	
a°	4°	12°	4°	12°

Note: Controlling dimensions are in millimeters. Approximate dimensions are provided in inches

DAA package outline - TDFN3x3-5

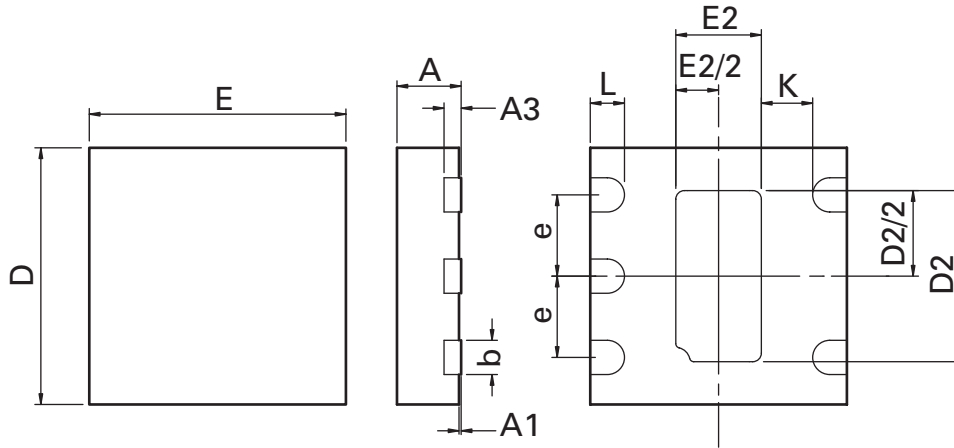

Dim.	Millimeters		Inches		Dim.	Millimeters		Inches	
	Min.	Max.	Min.	Max.		Min.	Max.	Max.	Max.
A	0.70	0.80	0.0276	0.0315	e	0.95REF		0.0374REF	
A1	0.00	0.05	0.00	0.002	E	3.00BSC		0.1181BSC	
A3	0.20REF		0.0079REF		E2	0.85	1.10	0.0335	0.0433
b	0.30	0.45	0.0118	0.0177	L	0.30	0.50	0.0118	0.0197
D	3.00BSC		0.1181BSC		K	0.20	-	0.0079	-
D2	1.85	2.10	0.0728	0.0827	-	-	-	-	-

Note: Controlling dimensions are in millimeters. Approximate dimensions are provided in inches

Definitions

Product change

Zetex Semiconductors reserves the right to alter, without notice, specifications, design, price or conditions of supply of any product or service. Customers are solely responsible for obtaining the latest relevant information before placing orders.

Applications disclaimer

The circuits in this design/application note are offered as design ideas. It is the responsibility of the user to ensure that the circuit is fit for the user's application and meets with the user's requirements. No representation or warranty is given and no liability whatsoever is assumed by Zetex with respect to the accuracy or use of such information, or infringement of patents or other intellectual property rights arising from such use or otherwise. Zetex does not assume any legal responsibility or will not be held legally liable (whether in contract, tort (including negligence), breach of statutory duty, restriction or otherwise) for any damages, loss of profit, business, contract, opportunity or consequential loss in the use of these circuit applications, under any circumstances.

Life support

Zetex products are specifically not authorized for use as critical components in life support devices or systems without the express written approval of the Chief Executive Officer of Zetex Semiconductors plc. As used herein:

A. Life support devices or systems are devices or systems which:

1. are intended to implant into the body

or

2. support or sustain life and whose failure to perform when properly used in accordance with instructions for use provided in the labelling can be reasonably expected to result in significant injury to the user.

B. A critical component is any component in a life support device or system whose failure to perform can be reasonably expected to cause the failure of the life support device or to affect its safety or effectiveness.

Reproduction

The product specifications contained in this publication are issued to provide outline information only which (unless agreed by the company in writing) may not be used, applied or reproduced for any purpose or form part of any order or contract or be regarded as a representation relating to the products or services concerned.

Terms and Conditions

All products are sold subjects to Zetex' terms and conditions of sale, and this disclaimer (save in the event of a conflict between the two when the terms of the contract shall prevail) according to region, supplied at the time of order acknowledgement.

For the latest information on technology, delivery terms and conditions and prices, please contact your nearest Zetex sales office.

Quality of product

Zetex is an ISO 9001 and TS16949 certified semiconductor manufacturer.

To ensure quality of service and products we strongly advise the purchase of parts directly from Zetex Semiconductors or one of our regionally authorized distributors. For a complete listing of authorized distributors please visit: www.zetex.com/salesnetwork

Zetex Semiconductors does not warrant or accept any liability whatsoever in respect of any parts purchased through unauthorized sales channels.

ESD (Electrostatic discharge)

Semiconductor devices are susceptible to damage by ESD. Suitable precautions should be taken when handling and transporting devices. The possible damage to devices depends on the circumstances of the handling and transporting, and the nature of the device. The extent of damage can vary from immediate functional or parametric malfunction to degradation of function or performance in use over time. Devices suspected of being affected should be replaced.

Green compliance

Zetex Semiconductors is committed to environmental excellence in all aspects of its operations which includes meeting or exceeding regulatory requirements with respect to the use of hazardous substances. Numerous successful programs have been implemented to reduce the use of hazardous substances and/or emissions.

All Zetex components are compliant with the RoHS directive, and through this it is supporting its customers in their compliance with WEEE and ELV directives.

Product status key:

"Preview"	Future device intended for production at some point. Samples may be available
"Active"	Product status recommended for new designs
"Last time buy (LTB)"	Device will be discontinued and last time buy period and delivery is in effect
"Not recommended for new designs"	Device is still in production to support existing designs and production
"Obsolete"	Production has been discontinued

Datasheet status key:

"Draft version"	This term denotes a very early datasheet version and contains highly provisional information, which may change in any manner without notice.
"Provisional version"	This term denotes a pre-release datasheet. It provides a clear indication of anticipated performance. However, changes to the test conditions and specifications may occur, at any time and without notice.
"Issue"	This term denotes an issued datasheet containing finalized specifications. However, changes to specifications may occur, at any time and without notice.

Zetex sales offices

Europe	Americas	Asia Pacific	Corporate Headquarters
Zetex GmbH Kustermann-park Balanstraße 59 D-81541 München Germany Telephone: (49) 89 45 49 49 0 Fax: (49) 89 45 49 49 49 europe.sales@zetex.com	Zetex Inc 700 Veterans Memorial Highway Hauppauge, NY 11788 USA Telephone: (1) 631 360 2222 Fax: (1) 631 360 8222 usa.sales@zetex.com	Zetex (Asia Ltd) 3701-04 Metroplaza Tower 1 Hing Fong Road, Kwai Fong Hong Kong Telephone: (852) 26100 611 Fax: (852) 24250 494 asia.sales@zetex.com	Zetex Semiconductors plc Zetex Technology Park, Chadderton Oldham, OL9 9LL United Kingdom Telephone: (44) 161 622 4444 Fax: (44) 161 622 4446 hq@zetex.com

© 2006 Published by Zetex Semiconductors plc