

**60V N-CHANNEL SELF PROTECTED ENHANCEMENT MODE IntelliFET™ MOSFET**

**SUMMARY**

Continuous drain source voltage  $V_{DS}=60V$

On-state resistance  $550m\Omega$

Nominal load current 1.6A

Clamping Energy 550mJ

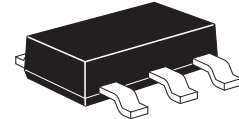

**DESCRIPTION**

Self protected low side MOSFET. Monolithic over temperature, over current, over voltage (active clamp) and ESD protected logic level power MOSFET intended as a general purpose switch.

**SOT223 PACKAGE**

**FEATURES**

- High continuous current rating
- Logic level input
- Input protection (ESD)
- Thermal shutdown with auto restart
- Over load protection
- Short circuit protection with pulse start capability and auto restart
- Over voltage protection (active clamp)
- Load dump protection (actively protects load)

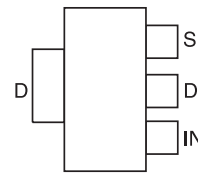

**PINOUT DIAGRAM**

**APPLICATIONS**

- Especially suited for loads with a high inrush current such as lamps and motors
- All types of resistive, inductive and capacitive loads in switching applications
- $\mu C$  compatible power switch for 12V and 24V DC applications and for 42V Powernet
- Automotive rated
- Replaces electromechanical relays and discrete circuits

**FUNCTIONAL BLOCK DIAGRAM**

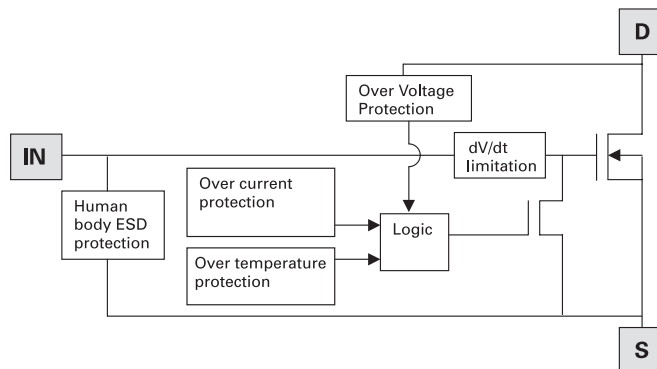

# BSP75G

## ADVANCE INFORMATION

### ABSOLUTE MAXIMUM RATINGS

PARAMETER	SYMBOL	LIMIT	UNIT
Continuous drain-source voltage	$V_{DS}$	60	V
Drain-source voltage for short circuit protection	$V_{DS(SC)}$	36	V
Continuous input voltage	$V_{IN}$	-0.2 ... +10	V
Peak input voltage	$V_{IN}$	-0.2 ... +20	V
Operating temperature range	$T_j$	-40 to +150	°C
Storage temperature range	$T_{stg}$	-55 to +150	°C
Power dissipation at $T_A = 25^\circ\text{C}$	$P_D$	2.5	W
Continuous drain current @ $V_{IN}=10\text{V}$ ; $T_A=25^\circ\text{C}$ <sup>2</sup>	$I_D$	1.6	A
Pulsed drain current @ $V_{IN}=10\text{V}$	$I_{DM}$	3	A
Unclamped single pulse inductive energy	$E_{AS}$	550	mJ
Load dump protection	$V_{LoadDump}$	80	V
Electrostatic discharge (Human Body Model)	$V_{ESD}$	4000	V
DIN humidity category, DIN 40 040		E	
IEC climatic category, DIN IEC 68-1		40/150/56	

#### NOTES

<sup>2</sup> For a device surface mounted on FR4 PCB measured at  $t \leq 10\text{s}$ .

### THERMAL RESISTANCE

PARAMETER	SYMBOL	VALUE	UNIT
Junction to ambient (a)	$R_{\theta JA}$	50	°C/W

## ADVANCE INFORMATION

## BSP75G

### ELECTRICAL CHARACTERISTICS (at $T_{amb} = 25^{\circ}\text{C}$ unless otherwise stated)

PARAMETER	SYMBOL	MIN.	TYP.	MAX.	UNIT	CONDITIONS
<b>STATIC</b>						
Drain-source clamp voltage	$V_{DS(AZ)}$	60	70	75	V	$I_D=10\text{mA}$
Off state drain current	$I_{DSS}$		0.1	3	$\mu\text{A}$	$V_{DS}=12\text{V}, V_{IN}=0\text{V}$
Off state drain current	$I_{DSS}$		3	15	$\mu\text{A}$	$V_{DS}=32\text{V}, V_{IN}=0\text{V}$
Input threshold voltage <sup>4</sup>	$V_{IN(th)}$	1	2.1		V	$I_D=10\text{mA}$
Input current	$I_{IN}$		0.7	1.2	mA	$V_{IN}=+5\text{V}$
Input current	$I_{IN}$		1.5	2.7	mA	$V_{IN}=+7\text{V}$
Input current	$I_{IN}$		4	7	mA	$V_{IN}=+10\text{V}$
Static drain-source on-state resistance	$R_{DS(on)}$		520	675	$\text{m}\Omega$	$V_{IN}=5\text{V}, I_D=0.7\text{A}$
Static drain-source on-state resistance	$R_{DS(on)}$		385	550	$\text{m}\Omega$	$V_{IN}=10\text{V}, I_D=0.7\text{A}$
Continuous load current <sup>2</sup>	$I_D$			1.6	A	$V_{IN}=10\text{V}$
Continuous load current <sup>2</sup>	$I_D$			1	A	$V_{IN}=5\text{V}$
Current limit <sup>3</sup>	$I_{D(LIM)}$	0.7	1.1	1.75	A	$V_{IN}=5\text{V}, V_{DS}>5\text{V}$
Current limit <sup>3</sup>	$I_{D(LIM)}$	2	3	4	A	$V_{IN}=10\text{V}, V_{DS}>5\text{V}$
<b>DYNAMIC</b>						
Turn-on time ( $V_{IN}$ to 90% $I_D$ )	$t_{on}$		4	20	$\mu\text{s}$	$R_L=22\Omega, V_{IN}=0$ to $10\text{V}, V_{BB}=12\text{V}$
Turn-off time ( $V_{IN}$ to 90% $I_D$ )	$t_{off}$		10	20	$\mu\text{s}$	$R_L=22\Omega, V_{IN}=10\text{V}$ to $0\text{V}, V_{BB}=12\text{V}$
Slew rate on (70 to 50% $V_{BB}$ )	$-dV_{DS}/dt_{on}$		6.5	10	$\text{V}/\mu\text{s}$	$R_L=22\Omega, V_{IN}=0$ to $10\text{V}, V_{BB}=12\text{V}$
Slew rate off (50 to 70% $V_{BB}$ )	$dV_{DS}/dt_{on}$		3.2	10	$\text{V}/\mu\text{s}$	$R_L=22\Omega, V_{IN}=10\text{V}$ to $0\text{V}, V_{BB}=12\text{V}$
<b>PROTECTION FUNCTIONS<sup>1</sup></b>						
Required input voltage for over temperature protection	$V_{PROT}$	4.5			V	
Thermal overload trip temperature	$T_{JT}$	150	175		$^{\circ}\text{C}$	
Thermal hysteresis			10		$^{\circ}\text{C}$	
Unclamped single pulse inductive energy $T_j=25^{\circ}\text{C}$	$E_{AS}$	550			mJ	$I_{D(ISO)}=0.7\text{A}, V_{BB}=32\text{V}$
Unclamped single pulse inductive energy $T_j=150^{\circ}\text{C}$	$E_{AS}$	200			mJ	$I_{D(ISO)}=0.7\text{A}, V_{BB}=32\text{V}$
<b>INVERSE DIODE</b>						
Continuous source drain voltage	$V_{SD}$			1	V	$V_{IN}=0\text{V}, -I_D=1.4\text{A},$

#### NOTES

<sup>1</sup> Integrated protection functions are designed to prevent IC destruction under fault conditions described in the datasheet. Fault conditions are considered as "outside" normal operating range. Protection functions are not designed for continuous, repetitive operation.

<sup>2</sup> For a device surface mounted on FR4 PCB measured at  $t \leq 10\text{s}$ .

<sup>3</sup> The drain current is limited to a reduced value when  $V_{ds}$  exceeds a safe value.

<sup>4</sup> Protection features may operate outside spec for  $V_{IN} < 4.5\text{V}$ .

# BSP75G

# ADVANCE INFORMATION

## PACKAGE OUTLINE

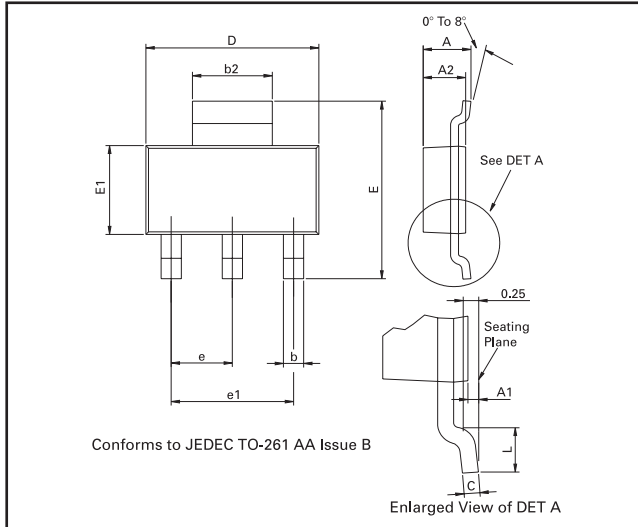

## PACKAGE DIMENSIONS

DIM	Millimeters		DIM	Millimeters	
	MIN	MAX		MIN	MAX
A	—	1.80	D	6.30	6.70
A1	0.02	0.10	e	2.30 BASIC	
A2	1.55	1.65	e1	4.60 BASIC	
b	0.66	0.84	E	6.70	7.30
b2	2.90	3.10	E1	3.30	3.70

© Zetex Semiconductors plc 2004

Europe	Americas	Asia Pacific	Corporate Headquarters
Zetex GmbH Streitfeldstraße 19 D-81673 München Germany	Zetex Inc 700 Veterans Memorial Hwy Hauppauge, NY 11788 USA	Zetex (Asia) Ltd 3701-04 Metroplaza Tower 1 Hing Fong Road, Kwai Fong Hong Kong	Zetex plc Lansdowne Road, Chadderton Oldham, OL9 9TY United Kingdom
Telefon: (49) 89 45 49 49 0 Fax: (49) 89 45 49 49 49 <a href="mailto:europa.sales@zetex.com">europa.sales@zetex.com</a>	Telephone: (1) 631 360 2222 Fax: (1) 631 360 8222 <a href="mailto:usa.sales@zetex.com">usa.sales@zetex.com</a>	Telephone: (852) 26100 611 Fax: (852) 24250 494 <a href="mailto:asia.sales@zetex.com">asia.sales@zetex.com</a>	Telephone (44) 161 622 4444 Fax: (44) 161 622 4446 <a href="mailto:hq@zetex.com">hq@zetex.com</a>

These offices are supported by agents and distributors in major countries world-wide.

This publication is issued to provide outline information only which (unless agreed by the Company in writing) may not be used, applied or reproduced for any purpose or form part of any order or contract or be regarded as a representation relating to the products or services concerned. The Company reserves the right to alter without notice the specification, design, price or conditions of supply of any product or service.

For the latest product information, log on to [www.zetex.com](http://www.zetex.com)



DRAFT ISSUE H - JUNE 2004